

# Actuator Name

## Typology (optional)

Fig.1  
Picture

Fig.2  
Mechanical interface  
drawings

Operating Data			
#	(quantity)	(unit)	(value)
Mechanical			
1	Continuous Output Power	[W]	xxx
2	Nominal Torque	[Nm]	xxx
3	Nominal Speed	[rad/s]	xxx
4	Nominal Stiffness Variation Time	with no load	[s] xxx
5		with nominal torque	[s] xxx
6	Peak (Maximum) Torque	[Nm]	xxx
7	Maximum Speed	[rad/s]	xxx
8	Maximum Stiffness	[Nm/rad]	xxx
9	Minimum Stiffness	[Nm/rad]	xxx
10	Maximum Elastic Energy	[J]	xxx
11	Maximum Torque Hysteresis	[%]	xxx
12	Maximum deflection	with max. stiffness	[°] xxx
13		with min. stiffness	[°] xxx
14	Active Rotation Angle	[°]	xxx
15	Angular Resolution	[°]	xxx
16	Weight	[Kg]	xxx
Electrical			
17	Nominal Voltage	[V]	xxx
18	Nominal Current	[A]	xxx
19	Maximum Current	[A]	xxx
Control			
20	Voltage Supply	[V]	xxx
21	Nominal Current	[A]	xxx
22	I/O protocol	[]	xxx

Fig.3  
Stiffness  
VS  
Torque

Fig.4  
Speed  
vs  
Torque

Fig.6  
Connection  
diagram

Fig.5  
Deflection  
vs  
Torque

# Actuator Name (repetition)

## Additional Characteristics

Fig.7  
Measured  
Torque  
vs  
Deflection

Fig.8  
3D workspace

Additional sensors data			
#	(quantity)	(unit)	(value)
a0	Sensor a		
a1	Resolution	[yyy]	xxx
a2	Range	[yyy]	xxx
a3	I/O protocol	[yyy]	xxx
ax	(specific sensor properties)	[yyy]	xxx
b0	Sensor b		
bx	(specific sensor properties)	[yyy]	xxx
by	(specific sensor properties)	[yyy]	xxx
bz	(specific sensor properties)	[yyy]	xxx
n0	Sensor n		
...	...	...	...

Fig.9  
Sensor Map

This space is left blank for any integrative information at the compiler's discretion. Examples may include:

- additional system images
- max. structural load values
  - accessories
  - software details

# Actuator Name (repetition)

## Model

Fig.10a  
Actuator Internals  
Layout

Fig.10b  
Actuator Internals  
Working Principle

## Mathematical model

101	Recoil Point Function	$x_e = x_e(q_1, q_2)$
102	Energy Function	$H = H(q_1, q_2, x)$
103	Output Torque Function	$\tau = \tau(q_1, q_2, x)$
104	Output Stiffness Function	$\sigma = \sigma(q_1, q_2, x)$
105	Spring Torque Function	$e_s = e_s(q_1, q_2, x)$
106	Springs to Motors Transmission Ratio	$A = A(q_1, q_2, x)$
107	Springs to Output Transmission Ratio	$B = B(q_1, q_2, x)$

## Legend

### Mechanical Operating Data

- 1 **Continuous Output Power:** product of Nominal Torque (3) and Nominal Speed (4).
- 2 **Nominal Torque:** torque the actuator can deliver for an unlimited amount of time without suffering performance losses.
- 3 **Nominal Speed:** speed reached by the actuator when powered at Nominal Voltage and applying a Nominal Torque.
- 4 **Nominal Stiffness Variation Time with no load:** time needed to achieve the maximum change of stiffness without load applied to the output shaft, using the peak torque of the motors, in the worst case (worst case between max. to min. stiffness and min. to max. stiffness)
- 5 **Nominal Stiffness Variation Time with nominal torque:** time needed to achieve the maximum change of stiffness with nominal torque applied to the output shaft, using the peak torque of the motors, in the worst case (worst case between max. to min. stiffness and min. to max. stiffness)
- 6 **Peak (Maximum) Torque:** maximum torque that the actuator can apply to the output shaft for a short period of time without suffering performance losses.
- 7 **Maximum Speed:** maximum speed at which the output shaft of the actuator can rotate for a short period of time without suffering performance losses.
- 8 **Maximum Stiffness:** maximum stiffness achievable by the actuator as derived from figure 8.
- 9 **Minimum Stiffness:** minimum stiffness achievable by the actuator as derived from figure 8.
- 10 **Maximum Elastic Energy:** maximum amount of energy the actuator can store in the springs.
- 11 **Maximum Torque Hysteresis:** maximum value of hysteresis on the experimental torque-deflection characteristic.
- 12 **Maximum deflection with maximum stiffness:** maximum physical deflection of the output shaft from an equilibrium point characterized by maximum stiffness.
- 13 **Maximum deflection with minimum stiffness:** maximum physical deflection of the output shaft from an equilibrium point characterized by minimum stiffness.
- 14 **Active Rotation Angle:** allowable actuated rotation amount, without considering passive deflection (#13 and #14)
- 15 **Angular Resolution:** resolution of the sensor on the output shaft.
- 16 **Weight:** overall weight of the actuator unit.

### Electrical Operating Data

- 18 - **Nominal Voltage:** continuous voltage at continuous nominal values of all other parameters.
- 19 - **Nominal Current:** current absorbed in the worst nominal working condition.
- 20 - **Maximum Current:** current absorbed in the worst working conditions.

### Control Operating Data

- 21 - **Voltage Supply:** nominal voltage required by control electronics to work properly.
- 22 - **Nominal Current:** current absorbed required by control electronics to work properly.
- 23 - **I/O protocol:** communication protocol to interface with control electronics.

### Additional sensors data

- a0 - **Sensor a:** identifier and type of particular sensor a.
- a1 - **Resolution:** ...
- a2 - **Range:** ...
- a3 - **I/O protocol:** ...
- ax - **(property x specific to sensor a):** ...
- b0 - **Sensor b:** ...
- bx - **(property x specific to sensor b):** ...
- n0 - **Sensor n:** ...
- nx - **(property x specific to sensor n):** ...

*to be defined depending on the particular sensor and typology.*

### Mathematical model

- 101 - **Equilibrium Point Function:** function relying the position of the unloaded output shaft given the positions of the motors.
- 102 - **Energy Function:** function relying the elastic energy stored in the elastic transmission given the position of the motors and the output shaft.
- 103 - **Output Torque Function:** function relying the output torque given the position of the motors and the output shaft.
- 104 - **Output Stiffness Function:** function relying the output stiffness given the position of the motors and the output shaft.
- 105 - **Spring Torque Function:** function relying the torque exerted on the springs given the position of the motors and the output shaft.
- 106 - **Springs to Motors Transmission Ratio:** derivative of the kinematic relation between deformations of the springs and position of the motors and output shaft with respect to the position of the motors.
- 107 - **Springs to Output Transmission Ratio:** derivative of the kinematic relation between deformations of the springs and position of the motors and output shaft with respect to the position of output shaft.

## Figures

A short description is reported for every figure along with an example.

**Fig. 1 – Picture:** An overall picture of the actuator as similar as possible to an isometric view. (Example should be photographic).



**Fig. 2 – Mechanical interface drawings:** Minimum number of views of the actuator with dimensions defining its size and physical interfaces. Views should comply to European drawing conventions.

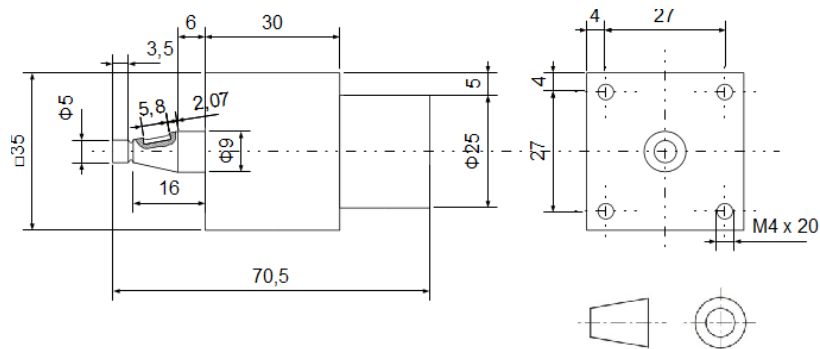

**Fig. 3 – Stiffness Vs Torque:** A two dimensional chart reporting the output stiffness (y axis) – output torque (x axis) curve.\*\*

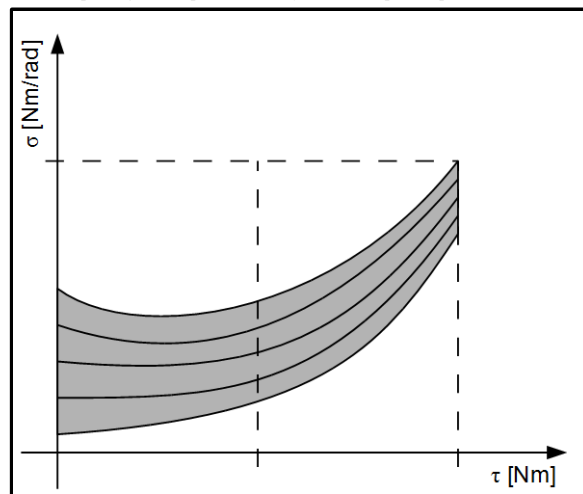

**Fig. 4 – Speed Vs Torque:** A two dimensional chart reporting the output speed (y axis) – output torque (x axis) curve.\*\*

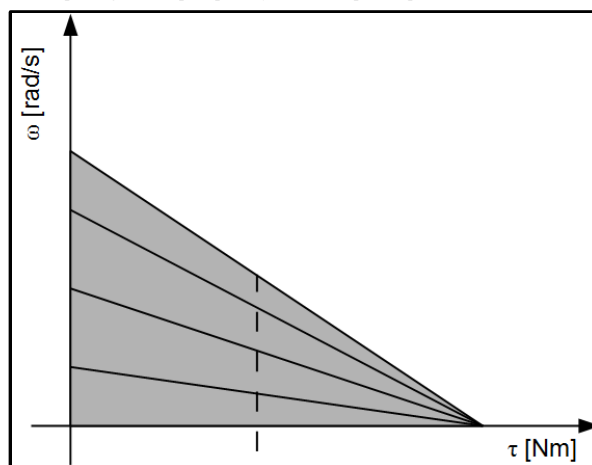

**Fig. 5 – Deflection Vs Torque:** A two dimensional chart reporting the output deflection (y axis) – output torque (x axis) curve.\*\*

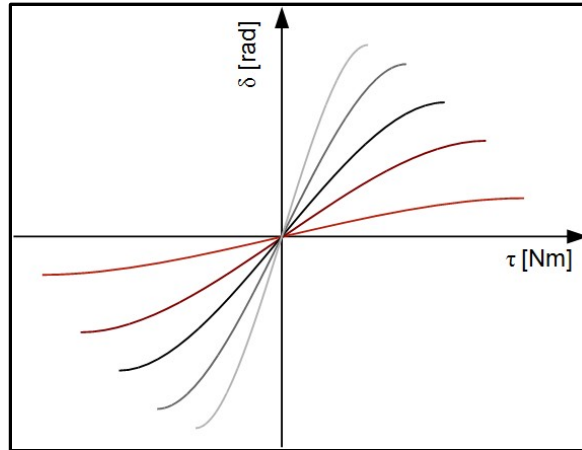

**Fig. 6 – Connection diagram:** The logical scheme showing electronic connections between actuator and external world.

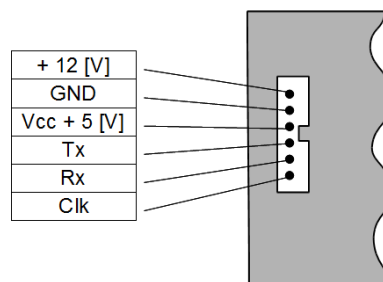

**Fig. 7 – Measured deflection Vs Torque:** A two dimensional chart reporting the measured output deflection (y axis) – output torque (x axis) curve.\*\*

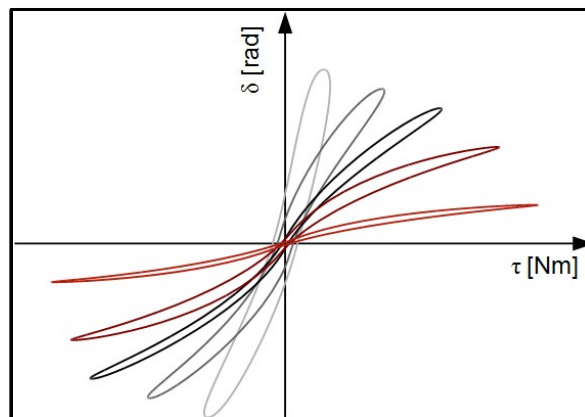

**Fig. 8 – 3D Workspace:** A three dimensional chart reporting the working volume of the actuator in the space defined by output torque (x axis) – output speed (y axis) – output stiffness (z axis).

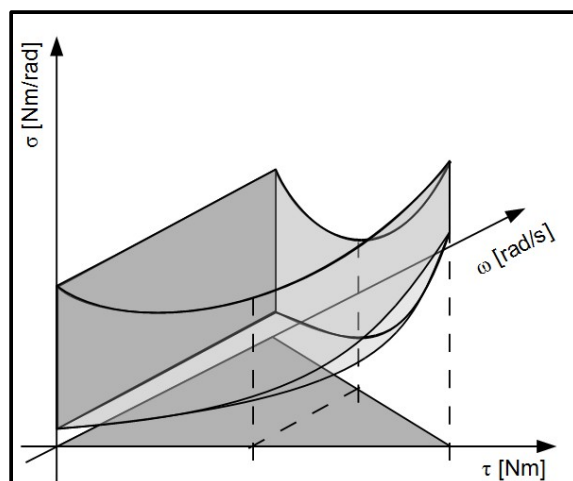

**Fig. 9 – Sensor map:** A logical scheme, with a sufficient detail level, showing the position and purpose of additional sensors inside the actuator.

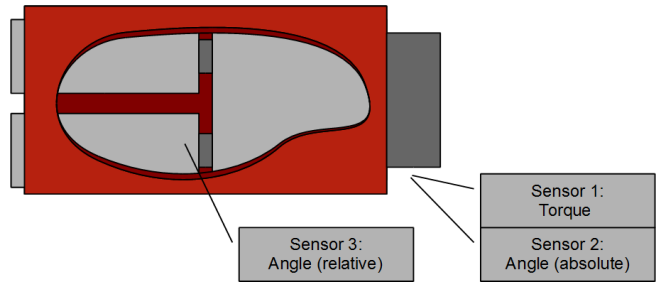

**Fig. 10a – Actuator internals – Layout:** Schematic drawing explaining internal layout of the actuator, representing interconnections among the components (motors, elastic transmission, output shaft).

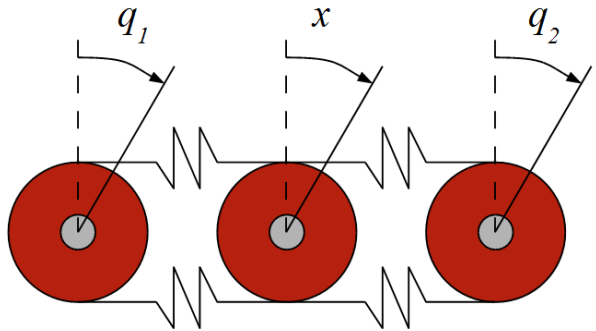

**Fig. 10b – Actuator internals – Working principle:** Schematic drawing explaining the working principle of the elastic transmission.

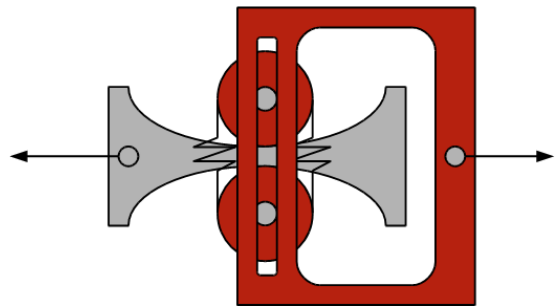

**Notes**

**Symbols.**

Symbols used in the mathematical model should be reported in the drawings of Figs. 10a and b, and in charts 3,4,5,7 and 8.

**\*\* Drawing conventions.**

Figures 3,4 and 5 report 5 curves each. The 5 lines describe the extremal limits of the Working Volume and three intermediate levels. The three intermediate lines represent the behavior of the system when applying three intermediate levels of preset stiffness, the 25, 50 and 75% of the no-load stiffness range. One more dashed line is present representing the nominal torque of the actuator.